

---

# High quality wood fibers for the MDF/HDF industry



Refiner System PR

# Only the best available solution on the market is good enough to serve our customers.

Infeed Material

Waste- and Fresh Wood Chips



Final Product

High Quality Flakes



## Application

The Pallmann Refining System PR produces high quality fiber for MDF/HDF and insulation boards made out of wood chips, sawdust and shavings as well as annual plants. Pallmann Refiner System reflects the optimum combination of experience gathered in practical operation and highly developed engineering skills. Each component of the system is designed for utmost reliability and economy in the board production process.

Constant improvements made together with and for our customers have resulted in a maintenance-friendly system with maximum availability. As a logical consequence of process knowledge and constant development of grinding segment technology, Pallmann offers you the solution for most economic and non-polluting production leading to optimum fiber quality for more than three decades. Chip quality and cleanliness are an important prerequisite for consistent high fiber quality and long service life of downstream machines. Efficient screening, followed preferably by wet cleaning with the Pallmann chip washing system PWH, offer these required advantages.

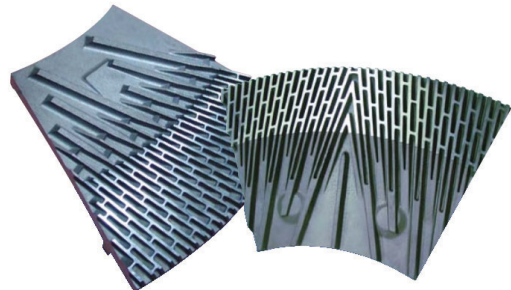

## Decisive Advantages and customer benefits

- › Heavy-duty design of all components to assure best refining conditions and long service life
- › Functional units completely assembled and test run in our workshop, allowing swift installation and commissioning
- › Maintenance-friendly design of single components maximizing up-time and minimizing spare part costs
- › Extra-long drainage and plug pipe section for even fiber moisture and economic dryer operation
- › Drop-in designed elements allowing swift exchange of wear and spare parts
- › Arrangement of discharge and feeding screw on the same level allows a very even dosing of chips into the grinding chamber
- › Refiner with a unique bearing assembly safely absorbing imposed thrust, giving maximum lifetime
- › Decision hydraulic gap adjustment for all Pallmann Refiners resulting in calibrated fiber
- › Pre-assembled grinding segments bolted from the rear to the segment holders without interruption of the grinding patterns = perfect preconditions for homogenous fiber quality
- › Reliable and virtually maintenance-free design of the blow valve and fiber diverter valve
- › PLC/HMI system combined with ample instrumentation allowing perfect process control and fine-tuning of the system

### 1. Chip bin for pre-steaming of chips

- The closed design of the bin with downward tapering base is equipped with vibrating motors to ensure a continuous discharge. Circular and inside steam injection results in perfect pre-conditioning of the chips
- Integrated load cells allow the online presentation of the filling level of the chips inside the bin



### 3. Blow-back valve

- The blow-back safety valve is located across from the plug screw. In the case of a production stop or a scarce supply with chips, this valve seals off digester and plug screw from each other
- This action is implemented by an extremely robust, pneumatically controlled steel cylinder

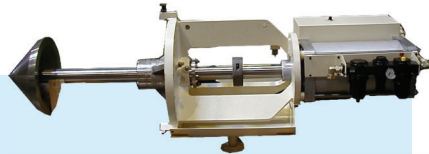

### 5. Pressurized refiner

- The Pallmann pressurized refiner is a single-disc refiner with one stationary and one adjustable rotating disc. To achieve consistent grinding conditions, the grinding segments are attached by screws from the rear and therefore generate no interruption of the grinding segment pattern.
- The grinding gap is controlled via a highly precise hydraulic servo system. The very narrow tolerances allow production of perfectly homogenous fiber quality
- For a quick change of the grinding segments, the housing is horizontally divided. Thus, the feed screw does not have to be removed when changing the grinding segments
- The quality and service life of the refiner bearing is unique in the industry. The hydrodynamic axial bearing can handle up to 12 MW of drive power
- Oil flow and pressure are constantly controlled during operation

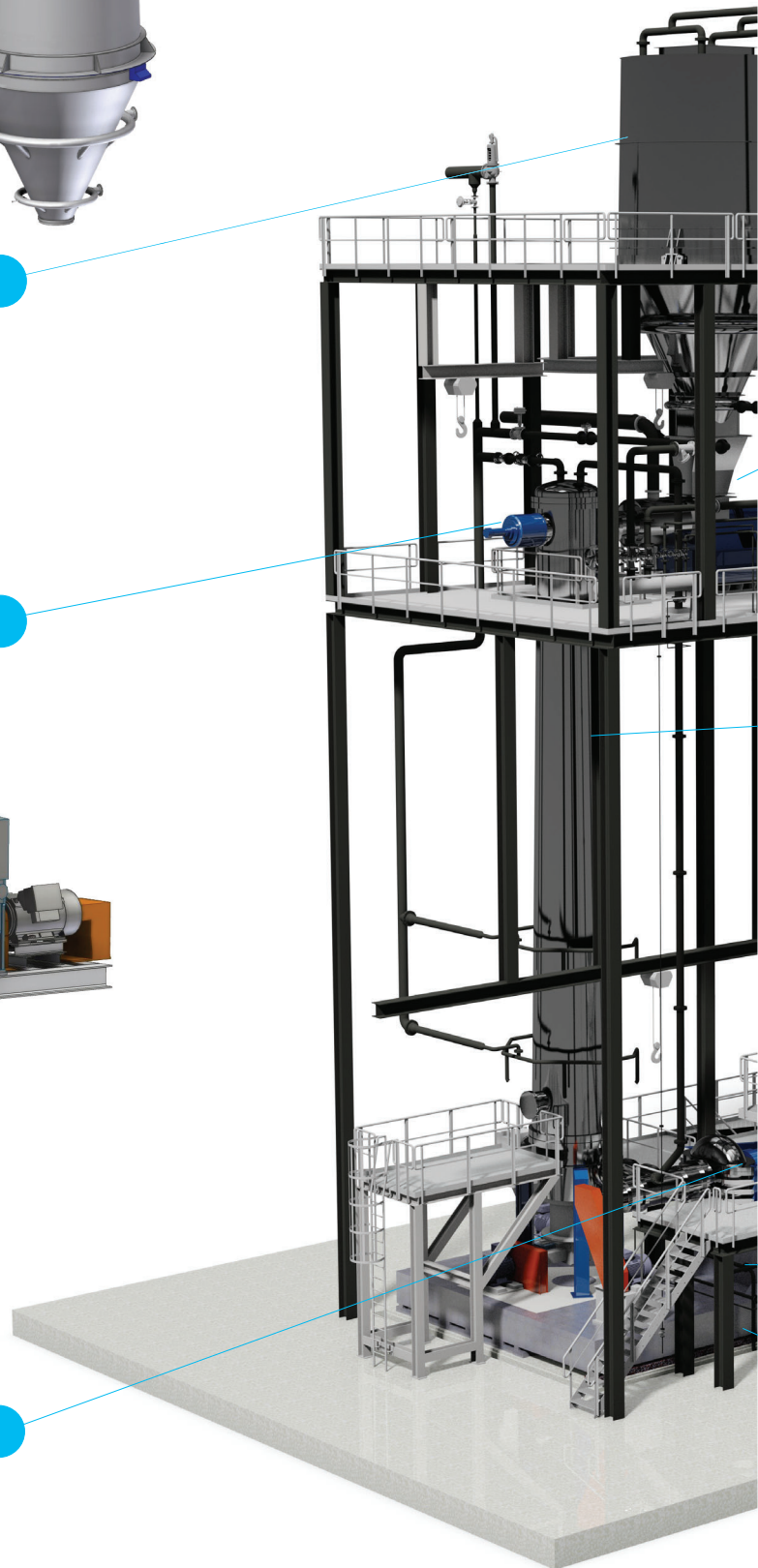
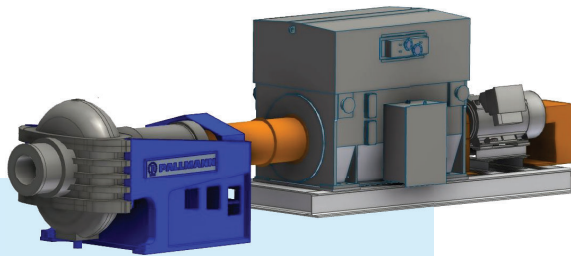

PR Refiner		PR 46	PR 50	PR 55
Disc Ø	mm	1.120 - 1.220	1.220 - 1.320	1.320 - 1.420
Capacity *	t b.d. / h	18,0 - 20,0	22,0 - 25,0	27,0 - 30,0

\* Depending on the wood species, conditions and machine settings

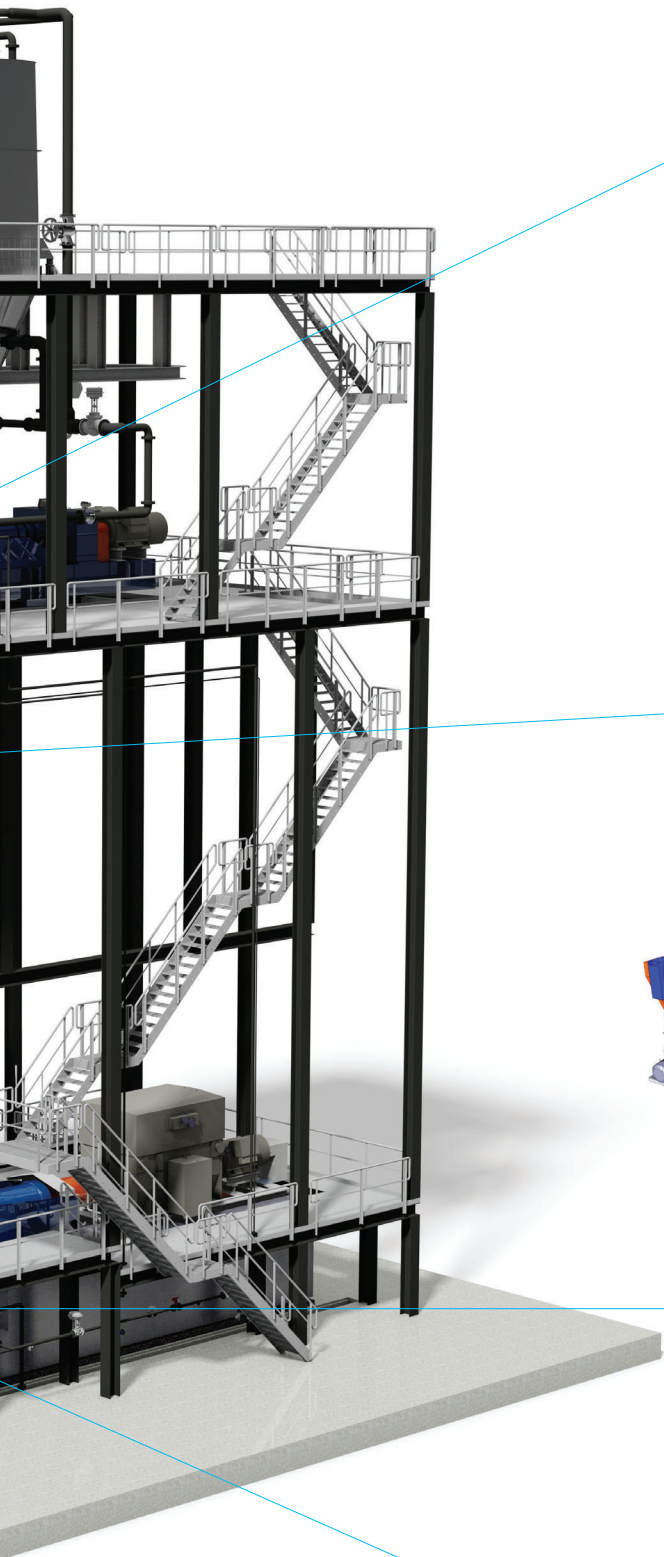

## 2. Plug screw

- The extremely heavy and robust plug screw feeds the chips reliably into the digester and squeezes out excess water
- The position compensation, caused by the thermal expansion of the digester, can be safely implemented by the special design of the robust base frame
- Due to the extended high-compression zone, a very even moisture adjustment can be ensured

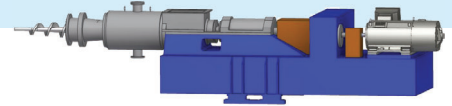

## 4. Digester

- The digester, made of stainless steel, is designed according to the pressure equipment directive and allows a gentle and safe cooking of the chips.
- Due to its tapered shape and large base diameter, maximum protection against plugging can be guaranteed.
- The flexibly adjustable level measurement controls fully-automatically the fill level and dwell time of the chips
- Via the agitator, frequency-controlled discharge screw and the feed screw, chips are fed into the pressurized refiner in a precisely defined amount.

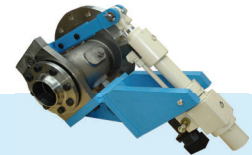
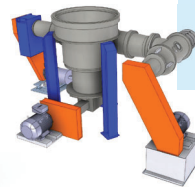

## 6. Discharge valve

- The fiber discharge to the dryer can be controlled by the adjustable, high-strength discharge valve. The unsurpassed resistance to wear and the absolutely reliable adjustment via a hydraulic cylinder are the special features of this valve.

## 7. Fiber diverter valve

- The very robust fiber diverter valve allows the automatic material flow changeover between production line / dryer and a startup cyclone and is completely maintenance-free.



	PR 58	PR 62	PR 66	PR 70
4	1.420 - 1.520	1.520 - 1.620	1.620 - 1.730	1.730 - 1.830
5,0	37,0 - 42,0	45,0 - 50,0	52,0 - 55,0	57,0 - 60,0

# Solutions available for various annual plants and natural fibers applications as well.



## Application

Due to the increased usage of wood-based fibers in various industries, this brings an increased need of alternative fiber sources. The rice and sugar industry for example can fill the gap. This valuable fiber can be treated and prepared using the refining system with horizontal digester.

The Heart of the Pallmann Refiner System reflects the optimum combination of experience gathered in practical operation and highly developed engineering skills. Each component of the system is designed for utmost reliability and economy in the board production process.

Constant improvements together with and for our customers have resulted in a maintenance-friendly system with maximum availability. As a logical consequence of process knowledge and constant development of grinding segment technology, Pallmann offers you the solution for most economic and non-polluting production leading to optimum fiber quality for more than three decades.

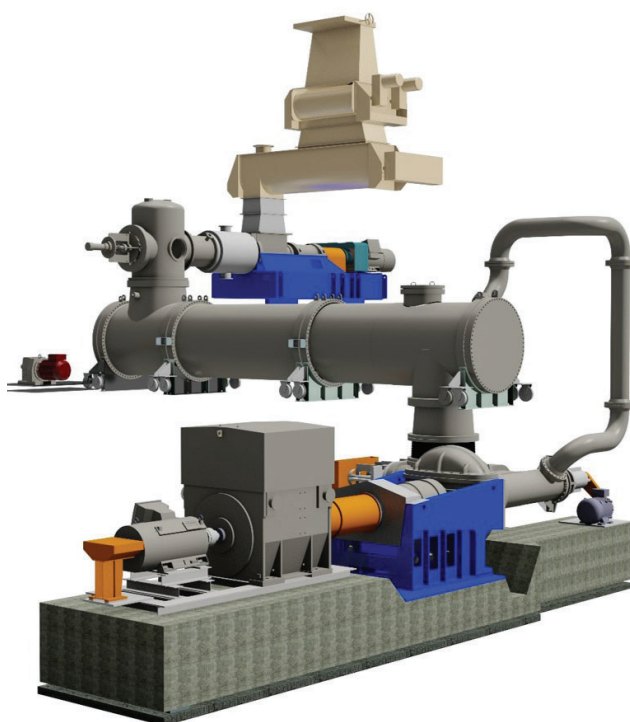
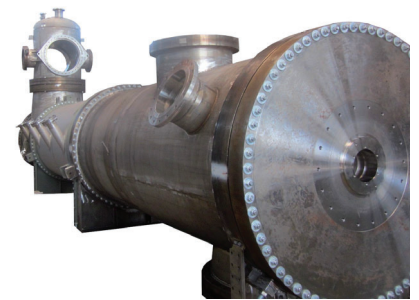

## Decisive Advantages and customer benefits

- › Heavy-duty design of all components to assure best refining conditions and long service life
- › Functional units completely assembled and test run in our workshop, allowing swift installation and commissioning
- › Maintenance-friendly design of single components maximizing up-time and minimizing spare part costs
- › Digester made of sections to allow ease of maintenance
- › Easy maintenance and high availability
- › Drop-in designed elements allowing swift exchange of wear and spare parts
- › Arrangement of discharge and feeding screw on the same level allows a very even dosing of chips into the grinding chamber
- › Refiner with a unique bearing assembly safely absorbing imposed thrust, giving maximum lifetime



#### **System solutions for:**

- Flake production
- Fiber production
- Recycling of waste wood
- Annual plants preparation
- Thermal usage

#### **Engineering and Service:**

- Design and Manufacturing
- Research and development
- Control Systems
- Process monitoring
- Spare and wear parts for size reduction machines in PALLMANN quality
- Installation, commissioning, start - up
- Maintenance and repair service
- Operator training
- Technological training
- Retrofit and modernisation
- Warehouse stocking programs and logistic concepts



**Any questions?  
We've got answers**

Pallmann is the leading manufacturer of size reduction machinery for the wood products industry. Pallmann designs, manufactures and supplies tailor-made, individual or complete solutions for the processing of raw material for MDF, OSB and particleboard plants. At its headquarters in Zweibrücken, PALLMANN company operates the world's largest research and development center for size reduction technology as well as a training and service center. Numerous machines are available for the preparation of various raw materials including subsequent laboratory analysis on individual scale. Our global presence is ensured by our sales network for machinery as well as spare parts and after-sales service.

[www.pallmann.eu](http://www.pallmann.eu)



Pallmann Maschinenfabrik GmbH & Co. KG  
Wolfslochstraße 51  
66482 Zweibrücken | Germany  
+49 6332 - 802 0  
[wood@pallmann.eu](mailto:wood@pallmann.eu)

**Intelligent engineering  
for future generations.**