

---

# Production of wood powder and surface layer flakes for the particleboard industry

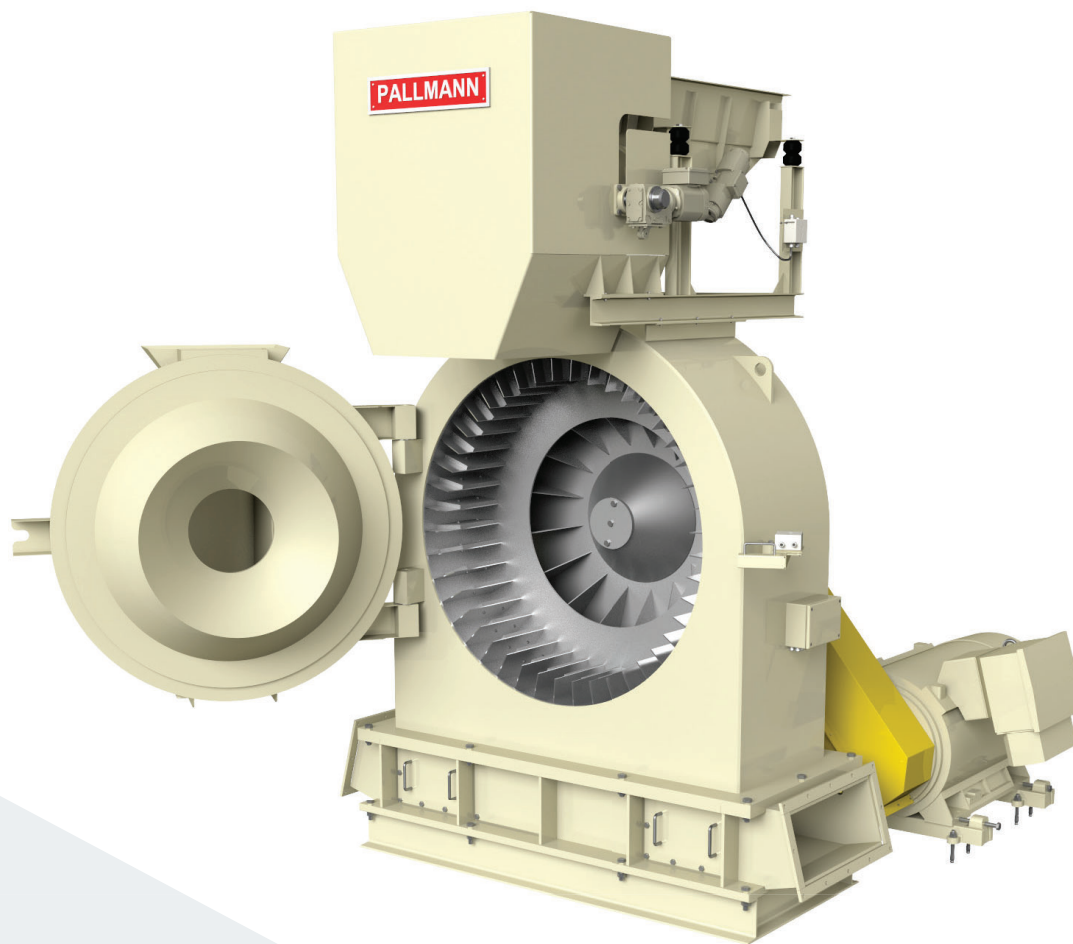

Double-Stream Mill PSKM



**SIEMPELKAMP**  
SIZE REDUCTION

# Compact and sturdy - proven technology for a long, safe and trouble-free operation.



## Area of Application

The Double-Stream mills PSKM are used to grind core layer flakes or oversize material from screening processes to fine surface layer flakes. In the wood-based materials industry they are the ideal solution when it comes to the further refinement of flakes. The produced fine flakes are used for laminated surface layers for panelboards. The PSKM flakes are also produced from planer shavings, milling flakes and saw dust as well as from all well-known annual plants such as bagasse, miscanthus, cotton stalks, hemp stalks, corn and rice straw.

## Design and Method of Operation

The fan effect of a multiple wing impeller pulls the feed material centrally into the grinding chamber passing through a special feed chute designed as a gravity separator for heavy material. The impeller, rotating at high speed, produces high air turbulence between the beater plates and the serrated profile of the grinding track. The double stream guides the feed material through this intensive turbulence in axial direction. The material is ground in the high velocity air stream by repeated impact onto the impeller beater plates and the grinding track profile.

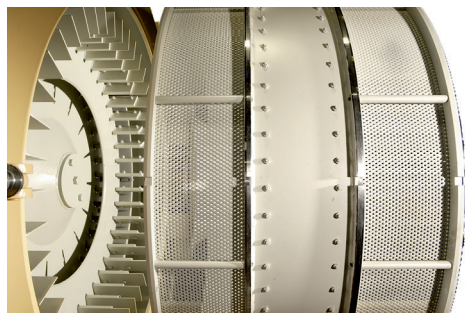
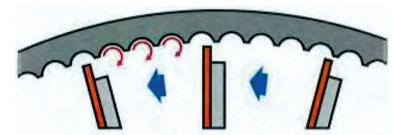
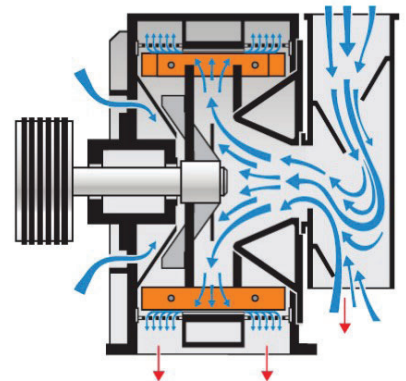

### "Out of the V" and "Into the V" grinding principle

Throughput capacity and fineness of the final product depend on various parameters and machine settings. This includes sort, moisture content, shape and size of the infeed material, as well as the gap between beater plates and grinding track, type of the screen and the grinding track profile inside the machine. Working „Out of the V“ means reduction of the retention time of the feed material on the central grinding track resulting in a coarser final product. Oppositely, the „Into the V“ grinding principle forces the infeed material to stay longer on the grinding track which leads to a finer product. Optionally the screens come in the split design, for easier installation, space saving storage and shipping.

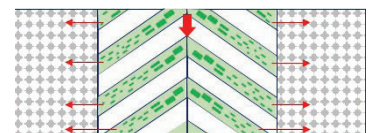
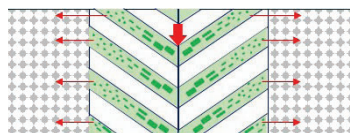

# Supplementary accessories for long life operation and adaption to different infeed materials.

## Gravity sifter type PF

- Improved removal of foreign objects in accordance with specific material density
- Adjustable material- and air guiding flaps for optimum adjustment to various feed materials and operating conditions
- Reduction of wood losses and reduction of spark occurrences
- Increased operational lifetime of all wear parts



## Overground suction box



- No pit or support structure is necessary for the machine
- Simple and quick installation
- Reduction of installation costs

## Wide grinding track without screen ring

- Grinding track divided in three sections
- No sifting effect inside the machine
- End product is discharged through the lateral gaps
- Grinding segments made of special wear-resistant material
- Grinding segments available in different design

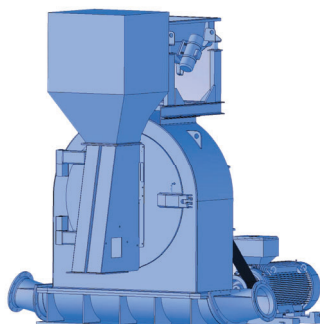
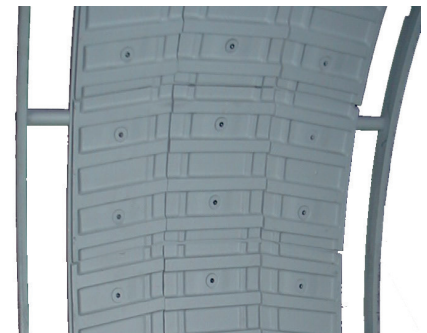

## Decisive Advantages

- › Homogeneous material preparation
- › Simple adjustment to the required fineness
- › Separation of heavy particles and ferrous metals
- › Compact design
- › Low maintenance

PSKM		12-600	14-660	15-720
Grinding track diameter	mm	1.200	1.400	1.500
Width of the grinding track	mm	210	230	250
Width of the screen ring	mm	2 x 180	2 x 200	2 x 220
Capacity *	t b. d. / h	1,3 - 3,2	1,8 - 4,2	2,3 - 5,3

\* Depending on the wood species, conditions and machine settings



#### **System solutions for:**

- Flake production
- Fiber production
- Recycling of waste wood
- Annual plants preparation
- Thermal usage

#### **Engineering and Service:**

- Design and Manufacturing
- Research and development
- Control Systems
- Process monitoring
- Spare and wear parts for size reduction machines in PALLMANN quality
- Installation, commissioning, start - up
- Maintenance and repair service
- Operator training
- Technological training
- Retrofit and modernisation
- Warehouse stocking programs and logistic concepts



Any questions?  
We've got answers

Pallmann is the leading manufacturer of size reduction machinery for the wood products industry. Pallmann designs, manufactures and supplies tailor-made, individual or complete solutions for the processing of raw material for MDF, OSB and particleboard plants. At its headquarters in Zweibrücken, PALLMANN company operates the world's largest research and development center for size reduction technology as well as a training and service center. Numerous machines are available for the preparation of various raw materials including subsequent laboratory analysis on individual scale. Our global presence is ensured by our sales network for machinery as well as spare parts and after-sales service.

[www.pallmann.eu](http://www.pallmann.eu)



Pallmann Maschinenfabrik GmbH & Co. KG  
Wolfslochstraße 51  
66482 Zweibrücken | Germany  
+49 6332 - 802 0  
[wood@pallmann.eu](mailto:wood@pallmann.eu)

Intelligent engineering  
for future generations.